

# Cahier technique n° 167

## Energy-based discrimination for low-voltage protective devices

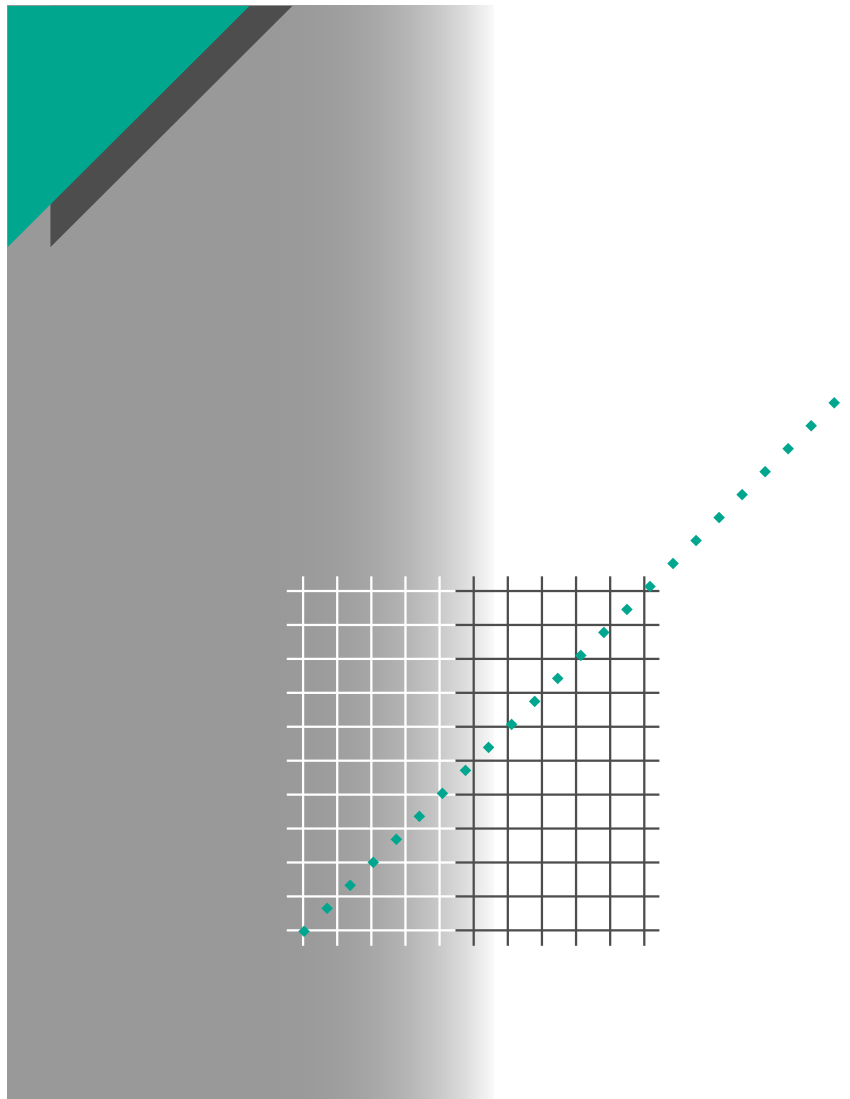

M. Serpinet  
R. Morel



GROUPE SCHNEIDER

“Cahiers Techniques” are a collection of documents intended for engineers and technicians people in the industry who are looking for information in greater depth in order to complement that given in display product catalogues.

These “Cahiers Techniques” go beyond this stage and constitute practical training tools.  
They contain data allowing to design and implement electrical equipment, industrial electronics and electrical transmission and distribution.  
Each “Cahier Technique” provides an in-depth study of a precise subject in the fields of electrical networks, protection devices, monitoring and control and industrial automation systems.

The latest publications can be downloaded on Internet from the Schneider server.

code: **<http://www.schneiderelectric.com>**

section: **mastering electrical power**

Please contact your Schneider representative if you want either a “Cahier Technique” or the list of available titles.

The “Cahiers Techniques” collection is part of the Groupe Schneider's “Collection Technique”.

### **Foreword**

The author disclaims all responsibility further to incorrect use of information or diagrams reproduced in this document, and cannot be held responsible for any errors or oversights, or for the consequences of using information and diagrams contained in this document.

Reproduction of all or part of a “Cahier Technique” is authorised with the prior consent of the Scientific and Technical Division. The statement “Extracted from Schneider “Cahier Technique” no..... (please specify)” is compulsory.

# n° 167

## Energy-based discrimination for low-voltage protective devices

---



**Marc SERPINET**

Joined Merlin Gerin in 1972 and worked until 1975 in the low-voltage equipment design offices, in charge of designing electrical cabinets for various installation layouts. Since 1975, he has managed research and development testing for low-voltage circuit-breakers. Graduated in 1981 from the ENSIEG engineering school in Grenoble. In 1991, after managing a Compact circuit-breaker project from the preliminary studies on through to production, he was appointed head of the electromechanical design office in charge of «anticipating» future developments.



**Robert MOREL**

Graduated with an engineering degree from ENSMM in Besançon and joined Merlin Gerin in 1971. Specialised in designing low voltage switchgear and participated in designing the Sellim system. In 1980, took over development of Compact circuit-breakers and Interpact switches. In 1985, became manager of the Low-Voltage Current Interruption design office in the Low-voltage Power Components division.

---

# Lexicon

---

**E<sub>b</sub>**

Energy let through by the protective device during breaking. This energy is characterised by  $\int i_b^2 dt \approx I^2 t_b$

**i<sub>b</sub>**

Limited short-circuit current actually flowing through the circuit-breaker (the break current is less than I<sub>p</sub>).

**I<sub>p</sub>**

Prospective short-circuit current that would develop in the absence of protective devices (rms value).

**I<sub>r</sub>**

Corresponds to the overload protection setting.

**t<sub>b</sub>**

The actual breaking time (arc extinction).

**UT**

Electronic processing unit.

**Actuator**

Device capable of producing a mechanical action.

**Circuit-breaker rating**

Corresponds to the models of the range (ex. 160 A, 250 A, 630 A, 800 A, etc.).

**Current-limiting circuit-breaker**

Circuit-breaker which, when interrupting a short-circuit current, limits the current to a value considerably less than the prospective current (I<sub>p</sub>).

**High-set instantaneous release (HIN)**

Instantaneous release used to limit thermal stress during a short-circuit.

**Instantaneous release (INS)**

Release without an intentional time delay system. It trips at a low multiple of I<sub>n</sub> to ensure short-circuit protection.

**Long-time release (LT)**

Release with an intentional time delay system (several seconds) for overload protection.

**Partial discrimination**

Discrimination is said to be partial when it is ensured only up to a certain level of the prospective current (I<sub>p</sub>).

**Selective circuit-breaker**

Circuit-breaker with an intentional time delay system (time discrimination).

**Short-time release (ST)**

Release with an intentional time delay system ranging from ten to several hundred milliseconds. If the time delay is reduced as I<sub>p</sub> increases, the system is referred to as dependent short-time (DST).

**Total discrimination**

Discrimination is said to be total when it is ensured for all values of the prospective fault current.

**Trip-unit rating**

Corresponds to the maximum current setting of the trip unit.

# Energy-based discrimination for low-voltage protective devices

The purpose of this “Cahier Technique” publication is to present the new energy-based discrimination technique that ensures tripping discrimination between protective devices during a short-circuit. Both simpler and more effective than standard discrimination techniques, it has been implemented on the Compact NS range of circuit-breakers used in low-voltage power distribution networks. Discrimination is ensured for all prospective fault currents on the condition that upstream and downstream circuit-breakers have different current ratings (ratio  $\geq 2.5$ ) with a trip-unit rating ratio  $\geq 1.6$ . Following a brief review of standard discrimination techniques, the authors examine the behaviour of circuit-breakers and various trip units from the energy standpoint.

They then demonstrate that total discrimination is possible up to the circuit-breaker breaking capacity, over several levels, without using time discrimination techniques.

## Contents

<b>1. Discrimination in low-voltage protective devices</b>	1.1 Definition	<b>p. 4</b>
	1.2 Enhanced safety and availability	p. 5
	1.3 Discrimination zones	p. 5
<b>2. Discrimination techniques for short-circuits</b>	2.1 Current discrimination	<b>p. 7</b>
	2.2 Time discrimination	p. 7
	2.3 “SELLIM” discrimination	p. 8
	2.4 Zone selective interlocking	p. 9
	2.5 Combining the different types of discrimination	p. 9
<b>3. Energy-based discrimination</b>	3.1 Choice of operating curves	<b>p. 10</b>
	3.2 Characterisation of a Compact NS circuit-breaker	p. 11
	3.3 Characterisation of the trip units	p. 13
<b>4. Advantages and implementation of energy-based discrimination</b>	4.1 Current-limiting circuit-breaker fitted with a pressure trip system	<b>p. 16</b>
	4.2 Discrimination with Compact NS circuit-breakers	p. 18
	4.3 Combination with traditional protective devices	p. 19
<b>5. Conclusion</b>		<b>p. 21</b>
<b>6. Appendix - indications concerning breaking with current limiting</b>		<b>p. 22</b>

# 1 Discrimination in low-voltage protective devices

## 1.1 Definition

In an electrical installation, loads are connected to sources via a succession of protection, isolation and control devices. This “Cahier Technique” publication deals essentially with the protection function using circuit-breakers.

In a radial feeder layout (see [fig. 1](#)), the purpose of discrimination is to disconnect only the faulty load or feeder from the network and no others, thus ensuring maximum continuity of service.

If discrimination studies are not or are incorrectly carried out, an electrical fault may cause several protective devices to trip, thus provoking an interruption in the supply of power to a large part of the network. That constitutes an abnormal loss in the availability of electrical power for those parts of the network where no fault occurred.

Several types of overcurrents may be encountered in an installation:

- overloads,
  - short-circuits,
  - inrush currents,
- as well as:
- earth faults,
  - transient currents due to voltage dips or momentary loss of supply.

To ensure maximum continuity of service, there must be coordination between protective devices.

Note that voltage dips may provoke unnecessary opening of circuit-breakers by actuating undervoltage releases.

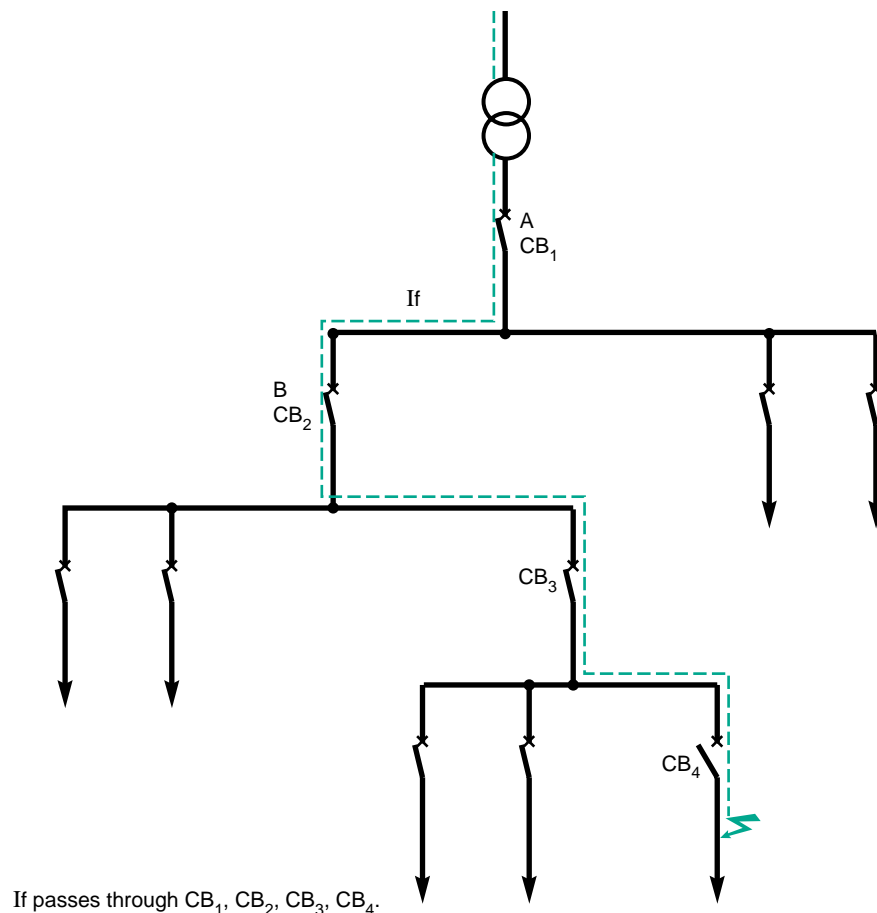

**Fig. 1:** several circuit-breakers are concerned by the fault *If*.

## 1.2 Enhanced safety and availability

A specific type of protective device exists for each type of fault (overloads, short-circuits, earth faults, undervoltages, etc.). However, a fault may simultaneously bring several types of protective devices into play, either directly or indirectly.

### Examples

- A high short-circuit current creates an undervoltage and may trip the undervoltage protective device.
- An insulation fault may be interpreted as a zero-phase sequence fault by an earth-leakage protective device and as an overcurrent by the short-circuit protective device (applicable for TN and IT earthing systems).
- A high short-circuit current may trip the earth-leakage protective device (in TT earthing systems) due to local saturation of the summation toroid which creates a false zero-phase sequence current.

For a given network, discrimination studies and the evaluation of the protection system in general are based on the protective device characteristics published by the manufacturers.

Studies begin with an analysis of requirements concerning protective devices needed for each type of fault. The next step is an evaluation of coordination possibilities between the protective devices concerned by a given fault. The result is improved continuity of service while still guaranteeing protection of life and property.

The following chapter will deal exclusively with discrimination in the event of overcurrents (overloads and short-circuits). In this context, the existence of discrimination between circuit-breakers is determined quite simply by whether several circuit-breakers open or not (see [fig. 2](#)).

### Total discrimination

Discrimination is said to be total if and only if, among the circuit-breakers potentially concerned by a fault, only the most downstream circuit-breaker trips and remains open, for all fault current values.

### Partial discrimination

Discrimination is said to be partial if the above condition is no longer valid for fault currents exceeding a certain level.

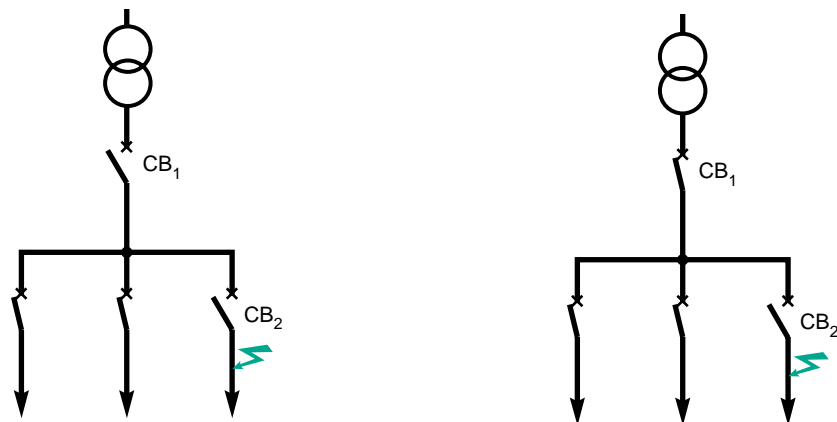

**a)** CB<sub>1</sub> and CB<sub>2</sub> open.  
⇒ discrimination is not ensured, i.e. power is not available for the feeders where no fault occurred.

**b)** CB<sub>1</sub> opens, CB<sub>2</sub> remains closed.  
⇒ discrimination is ensured, i.e. power is available for the feeders where no fault occurred (continuity of service).

*Fig. 2: circuit-breaker behaviour during a fault.*

## 1.3 Discrimination zones

Two types of overcurrent faults may be encountered in an electrical distribution network:

- overloads,
- short-circuits.

Overcurrents ranging from 1.1 to 10 times the service current are generally considered as overloads.

Overcurrents with higher values are short-circuits that must be cleared as rapidly as possible by instantaneous (INS) or short-time (ST) releases on the circuit-breaker.

Discrimination studies are different for each type of fault.

### Overload zone

This zone starts at the  $I_{LT}$  operating threshold of the long-time (LT) release. The tripping (or time-current) curve  $t_b = f(I_p)$  is generally of the inverse-time type to remain below the permissible thermal stress curve of the cables.

Using the most common method, the curves of the LT releases concerned by the fault are plotted in a system of log-log coordinates (see **fig. 3**).

For a given overcurrent value, discrimination is ensured during an overload if the non-tripping time of the upstream circuit-breaker  $CB_1$  is greater than the maximum breaking time (including the arcing time) of circuit-breaker  $CB_2$ . Practically speaking, this condition is met if the ratio  $I_{LT1}/I_{LT2}$  is greater than 1.6.

### Short-circuit zone

Discrimination is analysed by comparing the curves of the upstream and downstream circuit-breakers.

The techniques that make discrimination possible between two circuit-breakers during a short-circuit are based on combinations of circuit-breakers and/or releases of different types or with different settings designed to ensure that the tripping curves never cross.

A number of such techniques exist and are presented in the next chapter.

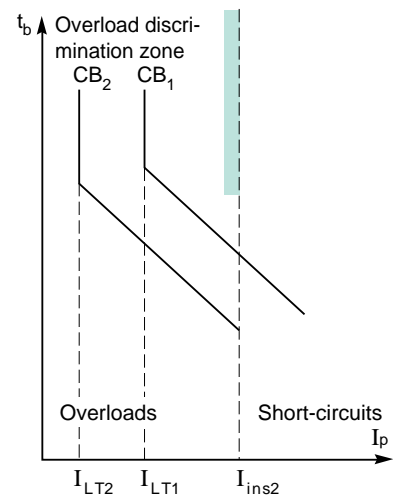

**Fig. 3:** overload discrimination.

## 2 Discrimination techniques for short-circuits

Several techniques can be used to ensure discrimination between two circuit-breakers during a short-circuit:

- current discrimination,
- time discrimination,

- “SELLIM” discrimination,
- zone selective interlocking,
- energy-based discrimination (see chapters 3 and 4).

### 2.1 Current discrimination

This type of discrimination is the result of the difference between the thresholds of the instantaneous or ST releases of the successive circuit-breakers.

Applied primarily in final distribution systems, it is implemented using rapid circuit-breakers not including an intentional tripping time-delay system.

It protects against short-circuits and generally results in only partial discrimination.

This form of discrimination is all the more effective when the fault currents are different, depending on where they occur in the network, due to the non-negligible resistance of conductors with small cross-sectional areas (see [fig. 4](#)).

The discrimination zone increases with the difference between the thresholds of the instantaneous releases on circuit-breakers  $CB_1$  and  $CB_2$  and with the distance of the fault from  $CB_2$  (low  $I_{sc} < I_{ins}$  of  $CB_1$ ).

The minimum ratio between  $I_{ins1}$  and  $I_{ins2}$  must be 1.5 to take into account threshold accuracies.

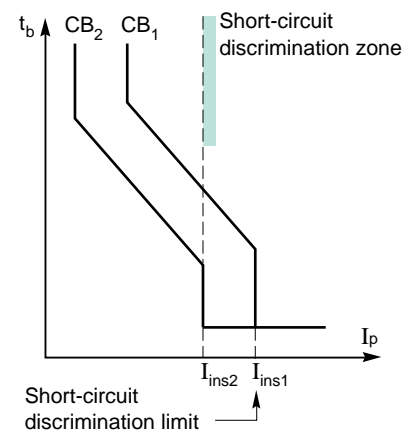

**Fig. 4:** current discrimination.

### 2.2 Time discrimination

To ensure total discrimination, the time-current curves of the two circuit-breakers must never cross, whatever the value of the prospective short-circuit current. For high fault currents, total discrimination is guaranteed if the horizontal sections of the curves to the right of  $I_{ins1}$  are not one on top of another.

Several solutions may be implemented to achieve total discrimination:

- the most common involves installing selective circuit-breakers including an intentional time-delay system,
- the second applies only to the last distribution stage and involves using current-limiting circuit-breakers.

#### Use of selective circuit-breakers

The term selective means that:

- the circuit-breaker trip unit has a fixed or adjustable time-delay system;
- the installation and the circuit-breaker can withstand the fault current for the duration of the intentional time delay (sufficient thermal and electrodynamic withstand capacities).

A selective circuit-breaker is generally preceded in the network by another selective circuit-breaker that has a longer intentional time delay.

Use of this type of circuit-breaker, corresponding to time discrimination solutions, results in total breaking times greater than 20 ms (one period)

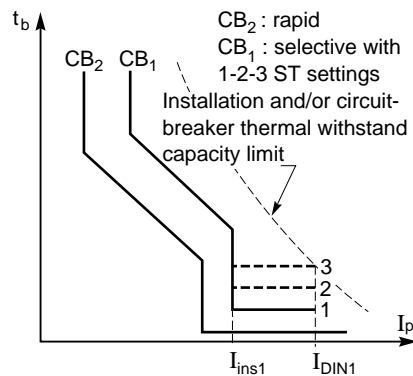

**Note:** use of a high-set instantaneous release determines the discrimination limit.

**Fig. 5:** time discrimination.

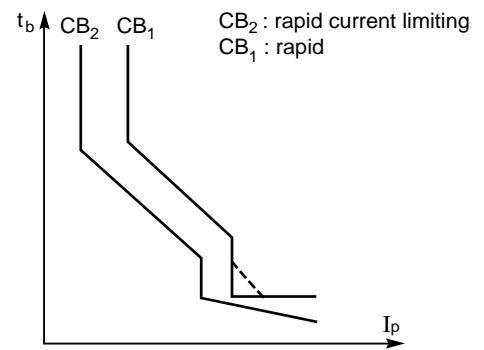

**Note:** use of dependent ST releases (dotted line) on CB<sub>1</sub> improves discrimination.

**Fig. 6:** pseudo-time discrimination.

in the event of a fault. This figure may run up to a few hundred milliseconds (see **fig. 5**).

When the installation (and perhaps even the circuit-breaker) cannot withstand a high short-circuit current ( $I_{sc}$ ) for the entire time delay, circuit-breaker CB<sub>1</sub> must be equipped with a high-set instantaneous release (HIN).

In this case, the discrimination zone is limited to the high-set threshold of the upstream circuit-breaker (see **fig. 5**).

#### Use of current-limiting circuit-breakers and “pseudo-time” discrimination

These circuit-breakers have two main characteristics:

- they severely limit short-circuit currents due to fast opening times and high arcing voltages,
- the higher the prospective short-circuit current, the faster they act.

Use of a current-limiting circuit-breaker downstream thus makes it possible to ensure “pseudo-time” discrimination between two protection levels. This solution, due to the current limiting effect and rapid clearing of the fault, limits thermal and electrodynamic stresses in the installation (see **fig. 6**).

## 2.3 “SELLIM” discrimination

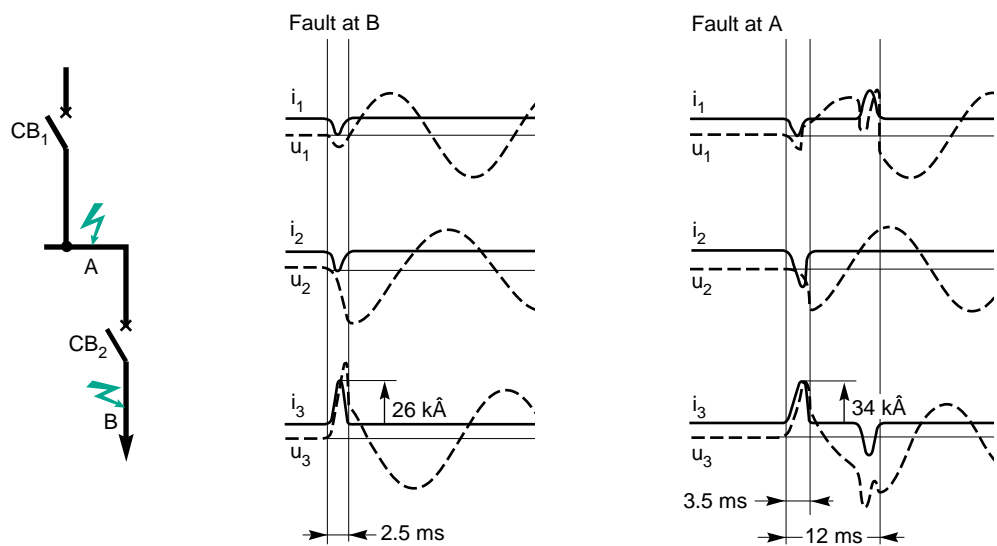

**Fig. 7:** “SELLIM” discrimination.  
(CB<sub>1</sub> - Compact C250 L SB  
CB<sub>2</sub> - Compact C125 N).

The "SELLIM" system offers a number of advantages: discrimination, cascading, reduced stresses in the installation. Upstream from a rapid circuit-breaker  $CB_2$ , the system requires an ultra current-limiting circuit-breaker  $CB_1$  fitted with a special release that does not trip during the first half-wave of the fault current (see **fig. 7**).

A major fault at B is detected by both circuit-breakers.  $CB_2$ , equipped with an instantaneous release, opens as soon as the fault current exceeds its

trip threshold and clears the fault in less than a half-period.  $CB_1$  detects only a single current wave and does not trip. The fault current nonetheless causes contact repulsion, thus limiting the current and the resulting stresses. This limiting of the fault current means that downstream circuit-breakers may have breaking capacities less than the prospective fault current. A fault at A causes repulsion of the contacts of the current-limiting circuit-breaker, thus limiting the stresses produced by the fault current.  $CB_1$  opens after the second half-wave of limited current.

## 2.5 Zone selective interlocking

This technique requires data transmission between the trip units of the circuit-breakers at the various levels in a radial feeder network.

The operating principle is simple (see **fig. 8**):

- each trip unit that detects a current greater than its tripping threshold sends a logic wait order to the next trip unit upstream,
- the trip unit of the circuit-breaker located just upstream of the short-circuit does not receive a wait order and reacts immediately.

With this system, fault clearing times remain low at all levels in the network.

Zone selective interlocking is a technique used with high-amp selective LV circuit-breakers, though its main application remains HV industrial networks. For further information, refer to "Cahier Technique" Publication Number 2, entitled "Protection of electrical distribution networks by the logic selectivity system".

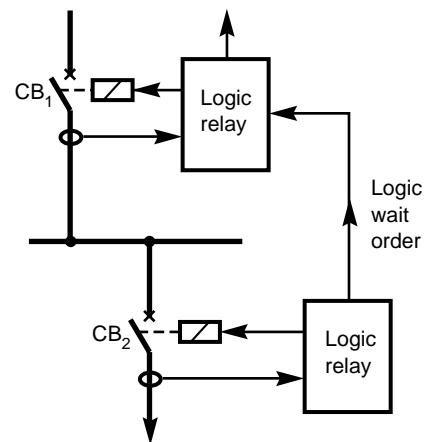

**Fig. 8:** zone selective interlocking.

## 2.6 Combining the different types of discrimination

The different types of discrimination presented above are generally combined to ensure the highest degree of availability of electrical power. See **figure 9** for an example.

Discrimination studies are still carried out using the tables supplied by manufacturers. The tables indicate the discrimination limits for each combination of circuit-breakers and for the various trip units.

The costs of non-discrimination and of the various devices selected are taken into account. The energy-based discrimination technique presented in the next chapter constitutes a true innovation that will considerably simplify LV discrimination studies and make possible total discrimination over several levels at minimum cost.

Circuits concerned	Type of discrimination				Type of circuit-breaker
	Zone selective interlocking	Time	"SELLIM"	Pseudo-time	
Head of LV network	[ ]				Selective logic
Power distribution	[ ]	[ ]			Selective Rapid/current limiting SELLIM
Final distribution				[ ]	Rapid
					Rapid/current limiting

**Fig. 9:** example of uses for different types of discrimination.

### 3 Energy-based discrimination

Energy-based discrimination is an improved and generalised version of the pseudo-time technique described in the preceding chapter. Discrimination is total if, for all values of  $I_p$ , the energy that the downstream circuit-breaker lets through is less than that required to actuate the trip unit of the upstream circuit-breaker.

The actual implementation of the energy-based discrimination principle is covered by a Merlin Gerin patent and has been incorporated in the design of the new Compact NS range of circuit-breakers.

These rapid and highly current-limiting circuit-breakers meet the rapidly evolving criteria of the market concerning:

- increases in installed power, which lead to higher short-circuit currents and correspondingly higher breaking capacities;

- the need to limit stresses in the installation as well as the level and duration of fault currents.

When reasoning in terms of energy and in order to understand energy-based discrimination, the choice of the means of presenting the operating curves is essential and the subject of the next section.

Following that discussion is an analysis of the behaviour in terms of energy for current-limiting circuit-breakers and the various trip units.

#### 3.1 Choice of operating curves

The  $t_b = f(I_p)$  curves commonly used for discrimination studies are of no use with current-limiting circuit-breakers when currents exceed  $25 I_n$  (breaking times are less than 10 ms at a frequency of 50 Hz).

Discrimination studies may no longer be carried out on the basis of periodic phenomena, but rather require analysis of transient phenomena. An understanding of energy-based discrimination requires that the following elements be characterised:

- the current wave that the circuit-breaker lets through during breaking, which is characterised by its Joule integral  $\int i^2 dt$  (often expressed as  $I^2 t$ ), and corresponds to the breaking energy  $E_b$ ,
- the sensitivity of the releases to the energy corresponding to the current pulse.

Thus, quite logically, the above characteristics are represented using  $I^2 t = f(I_p)$  curves instead of  $t_b = f(I_p)$  curves (see **fig. 10**). It should be noted that standard IEC 947-2 specifies characterisation of circuit-breakers using such curves.

For practical reasons the  $I^2 t = f(I_p)$  curve is presented in a system of log-log coordinates. For discrimination studies, the limits of the breaking  $I^2 t$  value ( $E_b$  for circuit-breakers) are between  $10^4$  and  $10^7 A^2 s$  for prospective currents ranging from 1 to 100 kA. Three powers of ten are therefore used for  $E_b$  and two for the current.

Assuming that the half-wave of the interrupted current is equivalent to half of a sine-wave with the same initial slope as the prospective current, the breaking energy  $E_b$  may be expressed as a function of  $I_p$  using the following expressions

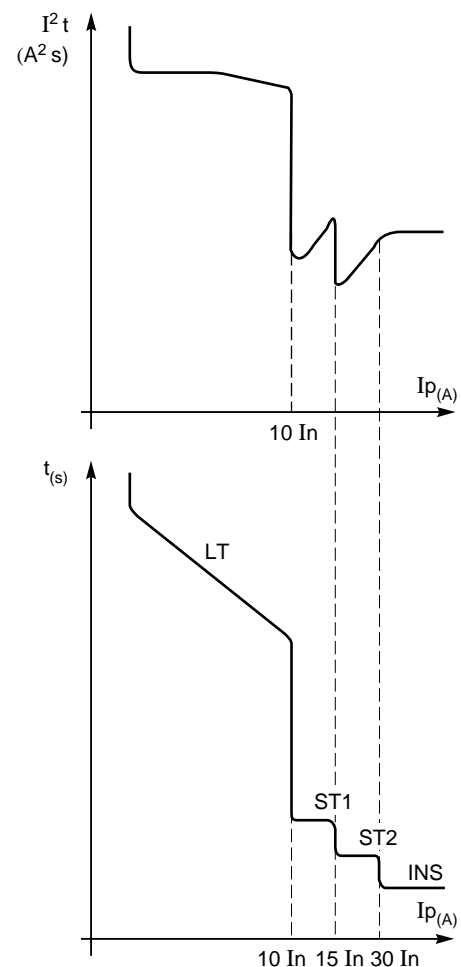

**Fig. 10:**  $t_b = f(I_p)$  and  $I^2 t = f(I_p)$  curves for a circuit-breaker equipped with an electronic trip unit.

(see the appendix on breaking with current limiting):

□ for  $t \geq 10$  ms

(2)  $\Rightarrow E_b = I_p^2 t$

□ for  $t < 10$  ms

(3)  $\Rightarrow E_b = 4 f^2 I_p^2 t_{vb}^3$

or

$$(4) \Rightarrow \frac{\hat{i}_b^3}{4 \sqrt{2} f I_p}$$

On the basis of these equations, the  $I_p^2 t / I_p$  system can be improved, thus providing further information on the virtual breaking time ( $t_{vb}$ ) and the limited peak current value ( $\hat{i}_b$ ).

#### Time lines (see fig. 11 )

A series of lines representing constant breaking times can be included in the log-log representation for a given frequency.

For example, when  $f = 50$  Hz, the line for:

■  $t = 20$  ms corresponds to the most common breaking time when  $I_p$  is greater than the

instantaneous thresholds and less than the contact repulsion threshold:

(2)  $\Rightarrow E_b = I_p^2 \times 2 \times 10^{-2}$ .

■  $t = 10$  ms is the breaking time at the current-limiting threshold:

(2)  $\Rightarrow E_b = I_p^2 \times 10^{-2}$ .

■  $t = 9$  to 4 ms which indicate circuit-breaker behaviour when current limiting:

(3)  $\Rightarrow E_b = I_p^2 t_{vb}^3 \times 10^4$ .

#### Peak-current lines

Similarly, on the basis of equation (4)

$$E_b = \frac{\hat{i}_b^3}{4 \sqrt{2} f I_p}$$

a series of lines corresponding to constant, limited peak currents can be included in the representation (see fig. 11 ).

It should be noted that this method of representation makes it possible to characterise circuit-breakers and trip units at 50 Hz for three-pole, two-pole and single-pole faults.

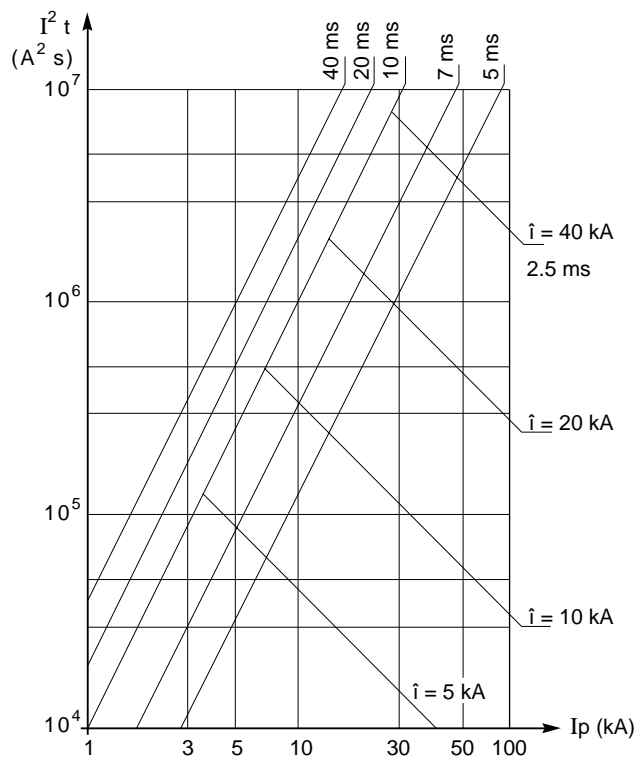

Fig. 11: graph representing energies.

## 3.2 Characterisation of a Compact NS circuit-breaker

### Display of the breaking $I^2 t$ value

The  $I^2 t$  values that a circuit-breaker lets through are determined by standardised type tests or by computer models run for a given voltage and frequency.

The curves presented here correspond to three-phase faults at 400V/50Hz.

The same curves may be generated for other voltages and other frequencies. The indicated values are the maximum values obtained

irrespective of the moment at which the fault occurs (upper limits) (see **fig. 12** ).

### Curve analysis

A great deal of information is available from the graph in **figure 12** which corresponds to a 250 A Compact NS circuit-breaker, equipped with a dependent ST (DST) electro-mechanical release with a  $10 I_n$  threshold.

The information characterises the different phases in the breaking behaviour of the current-limiting circuit-breaker depending on the value of the prospective short-circuit current  $I_p$ .

■ Point A: when the fault current reaches the trip threshold of the release, the breaking time is typically 50 ms for an INS or DST release.

■ Point B: when the fault current is greater than the trip threshold of the release, the breaking time drops and stabilises at 20 ms beginning at  $16 I_n$ .

■ Point C: when the fault current reaches the contact repulsion level, current limiting starts due to the insertion of an arc voltage in the circuit. Current limiting results in the return to in-phase conditions for the voltage and the current and consequently a drop in fault clearing times from 20 ms to 10 ms as  $I_p$  increases.

■ Point D: when the fault current reaches approximately 1.7 times the contact repulsion level, the energy is sufficient to totally open the contacts. At that point, the breaking time is typically 10 ms.

This reflex-type breaking is autonomous and a trip unit is required only to confirm the tripped status of the circuit-breaker and avoid untimely reclosing of the contacts.

■ Zone E: when the fault currents runs beyond 2 times the contact-repulsion level, current limiting is increasingly effective and results in increasingly short breaking times.

■ Point F: the end of the curve represents the breaking capacity limit of the circuit-breaker.

The curve provides a great deal of information:

- tripping threshold ( $I$  threshold, point A);
- breaking  $I^2 t$  value as a function of the prospective current;
- contact-repulsion level ( $I_r$ , point C);
- breaking capacity (point F);
- breaking time ( $t_{vb}$ ) as a function of the prospective current;
- limited peak current ( $\hat{i}_b$ ) as a function of the prospective current;
- current value above which  $t_{vb} < 10$  ms (beginning of current limiting).

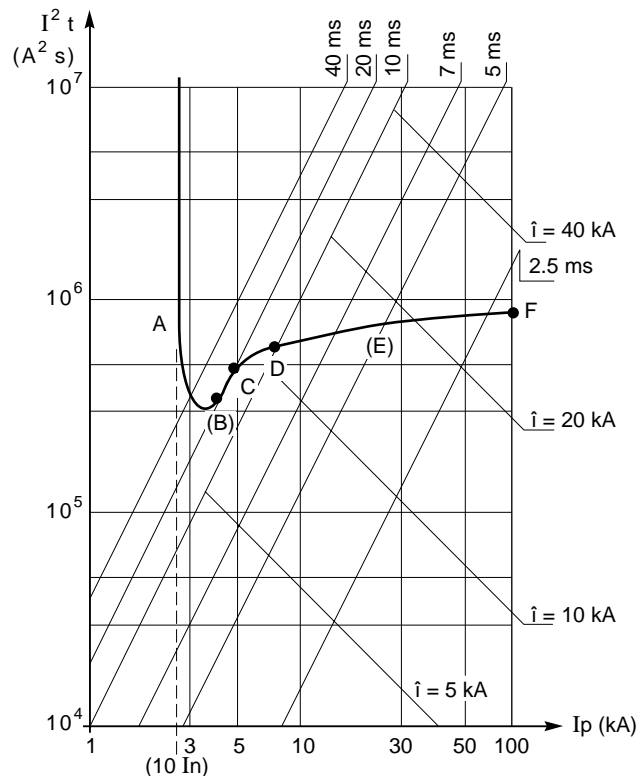

**Fig. 12:** breaking curve for a current-limiting circuit-breaker.

### 3.3 Characterisation of the trip units

Trip units are characterised by their response time to a given current (full-wave, half-wave, etc.).

By modifying the duration and the peak value of the current, which corresponds to the various currents limited by a circuit-breaker, a number of tests can be run to obtain a series of points which may be plotted on the previously described graph, thus producing the curve characterising a trip unit.

#### Magnetic trip units

##### ■ Instantaneous release

Generally made up of a magnetic U and a blade, it ensures short-circuit protection. The response time is under 50 ms at its operating threshold (between 5 and 10 times the rated current), then drops rapidly to below 10 ms when the current increases (see **fig. 13**).

##### ■ High-set release

As indicated in the time discrimination section, the role of high-set releases in time discrimination systems is to limit thermal stresses (see **fig. 5**) in the installation and the circuit-breaker.

The high-set release is an instantaneous unit with a threshold of 15 to 50  $I_n$ . The release may be either electro-mechanical or electronic.

##### ■ Constant time-delay release

This is an instantaneous release fitted with a “clock-type” time delay system intended to make tripping selective with respect to the downstream circuit-breaker.

The time delay may range from 10 to 500 ms and is generally set using notched dials.

**Figure 13** shows the curve (20 ms setting) for a short-time delay.

If the thermal stress ( $I^2 t$ ) resulting from a long time delay must be limited, the high-set release enters into play (see **fig. 13**).

##### ■ Dependent time delay release (function of $I_p$ , dependent short-time - DST)

The time delay results from the inertia of a mass and is therefore inversely proportional to  $I_p$  (see **fig. 13**).

#### Electronic trip units

The instantaneous thresholds in electronic trip units are sensitive to the rms value or the peak

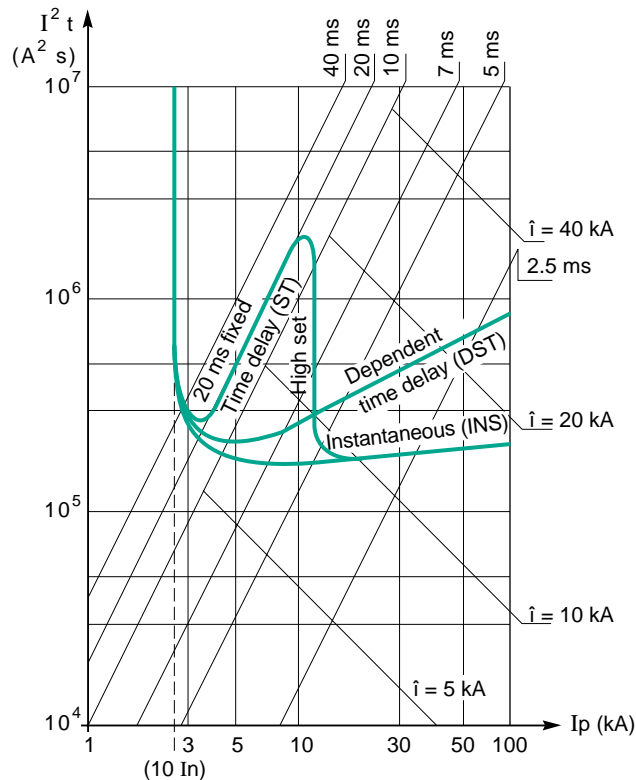

**Fig. 13:** curves for various magnetic releases.

current value. For high fault currents, their  $I^2 t$  characteristic is theoretically a straight line ( $\hat{t}_b = \text{constant}$ ).

In fact, the above is true for current pulse durations greater than the response time of the actuating elements of the trip unit (generally 4 ms). Below this value, the inertia of the mechanical elements of the trip unit produces, for high  $I_p$  values, a characteristic similar to that of an instantaneous electro-mechanical release.

The trip unit must therefore be characterised by its  $E_b = f(I_p)$  curve by carrying out tests identical to those for magnetic trip units.

These trip units may be of either the instantaneous or time delay type.

It is possible to combine several types of electronic trip units, for example:

- 10 to 15  $I_n$  - ST (40 ms),
- 15 to 30  $I_n$  - ST (10 ms),
- $> 30 I_n$  - INS.

**Figure 14** is an illustration of this example. The curves for this combination should be compared

with those in **figure 10** for the breaking energies of the circuit-breaker.

#### Trip units with arc detection

Generally combined with electronic trip units, arc detectors may be used to provide protection for:

- a cubicle: if an arc occurs in a cubicle, the detector orders opening of the incoming circuit-breaker,

- a selective circuit-breaker: positioned in the breaking unit, the detector provokes via the electronic trip unit the instantaneous tripping of the circuit-breaker.

The circuit-breaker is thus self-protected and can therefore be used up to the limit of its electrodynamic withstand capacity.

#### Pressure trip system

The pressure that develops in the breaking unit of a circuit-breaker is a result of the energy produced by the arc.

Above a certain fault current level, this pressure may be used for detection and tripping.

This is possible by directing the expanding gases

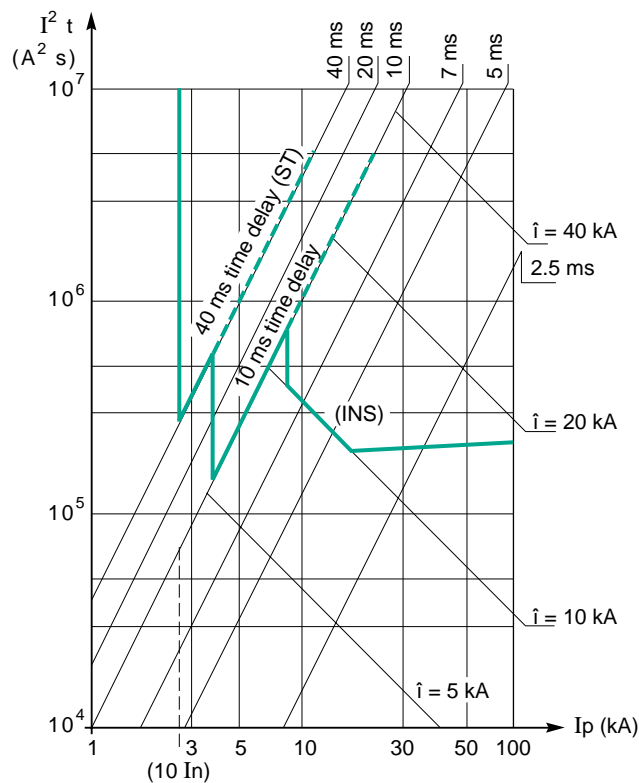

**Fig. 14:** examples of combinations of electronic trip-unit curves.

in the unit toward a piston that trips the circuit-breaker (see **fig. 15**).

Pressure trip systems may be used to:

- ensure self-protection of a selective circuit-breaker (similar to the arc detector),
- improve breaking and operating reliability of a rapid current-limiting circuit-breaker.

If each circuit-breaker is fitted with a correctly designed pressure trip system, discrimination is

ensured between circuit-breakers with different ratings for all overcurrents greater than 20 In.

It is this energy-based trip system (constant  $I^2 t$  value) that makes possible the energy-based discrimination technique employed in the Compact NS current-limiting circuit-breakers.

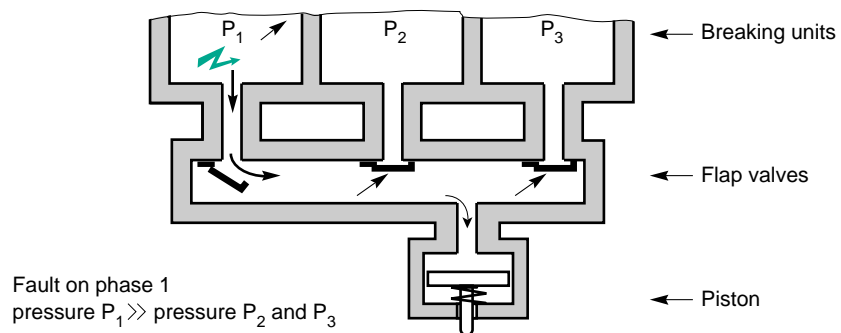

**Fig. 15:** operation of the pressure trip system.

## 4 Advantages and implementation of energy-based discrimination

Note that the circuit-breaker trip-unit system, whether electromechanical, electronic or a combination of the two, must offer the following features:

- minimum stresses in the installation (limited  $\hat{i}$  and  $I^2 t$  values),

- tripping dependability (safety),
- minimum disturbance for correctly functioning circuits (voltage dips),
- ease of discrimination studies.

### 4.1 Current-limiting circuit-breaker fitted with a pressure trip system

The above requirements may best be met with a pressure trip system, combined with either an electromechanical or electronic trip unit.

**Figure 16** indicates the “energy sensitivity” of this combination. The higher the prospective short-

circuit current, the shorter the response time, which leads to a virtually constant tripping time at  $I^2 t$ .

The energy let through by the current-limiting circuit-breaker during a break follows the same curve, but with a slight shift.

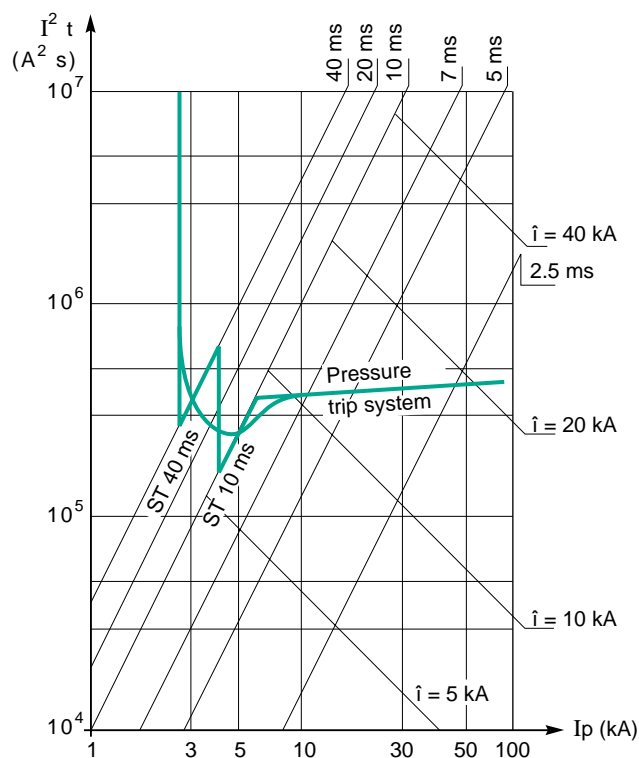

**Fig. 16:** trip-unit combination curves (electromagnetic and pressure or electronic and pressure).

### Stresses in the installation

Stresses are limited compared to those observed in current-limiting circuit-breakers of the previous generation.

On the basis of the example in **figure 16**, the figures for a Compact NS 250 A and an  $I_p$  of 40 kA are:

- 4 ms for the breaking time;
- 20 kA for the peak current;
- $8 \times 10^5 \text{ A}^2 \text{ s}$  for the  $I^2 t$ .

### Tripping dependability

The pressure trip system is a part of the opening mechanism for short-circuits and therefore depends on the current rating of the circuit-breaker.

The adjustable DST release, whether electromechanical (see **fig. 13**) or electronic (see **fig. 14**), is physically independent of the pressure trip system. Physical independence enhances operating dependability.

### Voltage dips

Voltage dips in an installation can trip undervoltage releases in circuit-breakers and contactors.

Unnecessary opening, following a voltage dip caused by a short-circuit, results in reduced continuity of service.

Consequently, discrimination studies must also take into account the reactions of undervoltage releases and contactors during voltage dips.

A voltage dip in a network lasts until the arc voltage that opposes the source voltage enables interruption of the current. It follows that the voltage dip depends on the type of circuit-breaker and/or trip unit used:

- with non-limiting circuit-breakers, the voltage dip is more pronounced and can last from 10 to 15 ms (see **fig.17**),
- with current-limiting circuit-breakers, the rapid development of a high arc voltage reduces the voltage dip both in duration and in amplitude (see **fig.17**).

The voltage dip lasts approximately 5 ms and amounts to 50 % of the rated voltage for currents close to the level required for contact repulsion. The voltage dip amounts to 30 % of the rated voltage for higher currents, but the duration is reduced to 3 to 4 ms. The higher the  $I_{sc}$ , the shorter the voltage dip.

Any undervoltage releases equipping the circuit-breakers are not affected by such voltage dips.

### Discrimination

The severely limited energy let through by the circuit-breaker is insufficient to trip the trip unit on

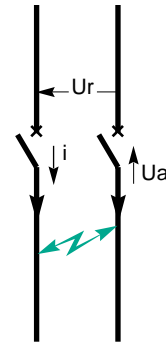

a) non-limiting circuit-breaker

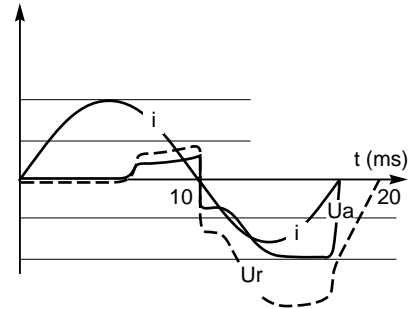

b) highly limiting circuit-breaker

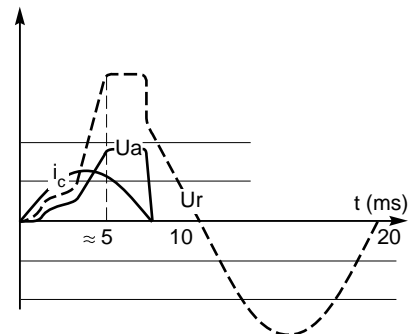

**Fig. 17:** the voltage dip on the network depends on the type of circuit-breaker.

the upstream circuit-breaker which remains closed.

## 4.2 Discrimination with Compact NS circuit-breakers

Using the energy-based discrimination technique and depending on the ratios between the upstream and downstream circuit-breaker ratings and the trip unit ratings, the Compact NS range (100, 160, 250, 400 and 630 A) offers either partial or total discrimination up to the breaking capacity.

### Total discrimination

**Figure 18** provides an example of total discrimination up to 100 kA over three levels with 100 A, 250 A and 630 A circuit-breakers fitted with various trip units.

Using Compact NS circuit-breakers, discrimination is total up to 150 kA.

To ensure total discrimination, the energy that a circuit-breaker lets through must be less than that required to trip the upstream circuit-breaker.

### General rule

**Discrimination is total and without any restrictions if:**

- the ratio between the ratings of the successive circuit-breakers is equal to or greater than 2.5,
- the ratio between the trip unit ratings is greater than 1.6.

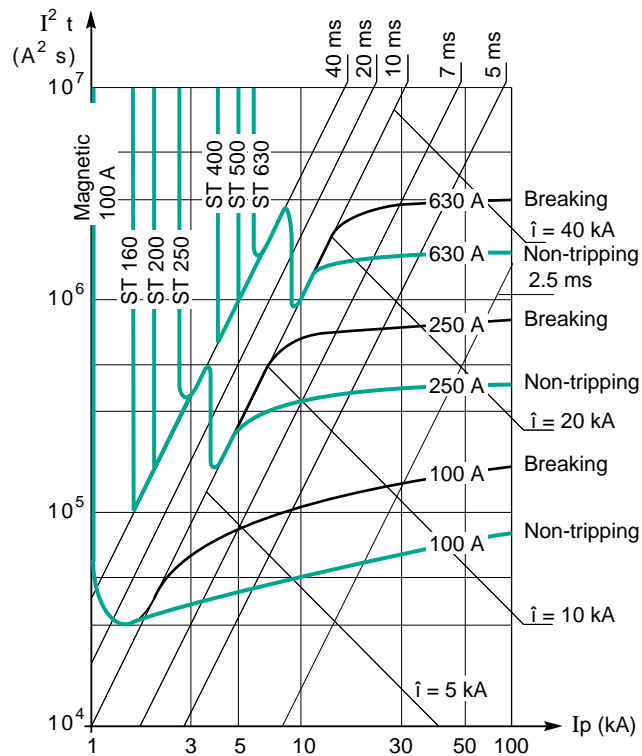

### Note

ST 160, ST 200 and ST 250: electronic trip units for 250 A circuit-breakers.

ST 400, ST 500 and ST 630: electronic trip units for 630 A circuit-breakers.

**Fig. 18:** total discrimination between 100 A, 160 A and 250 A Compact NS circuit-breakers.

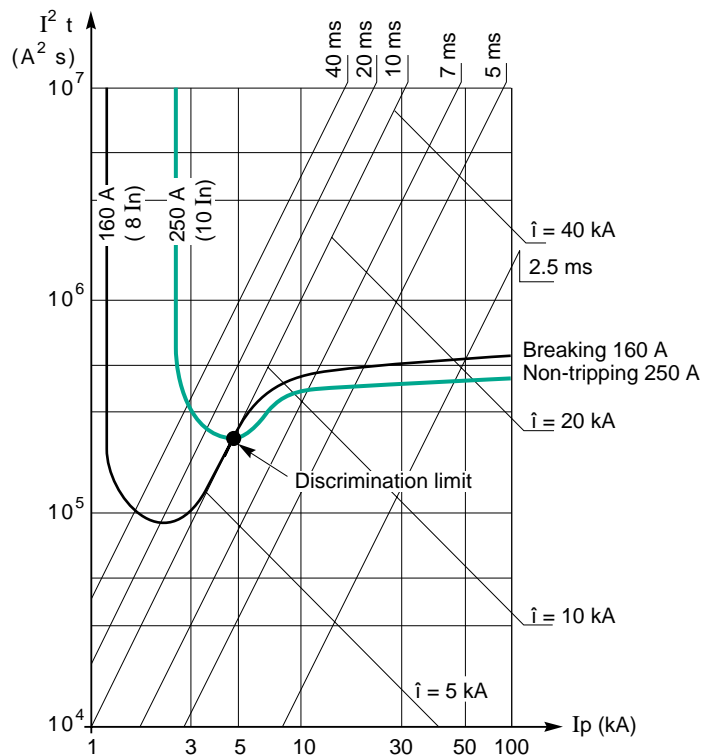

**Fig. 19:** partial discrimination between two Compact NS circuit-breakers, 160 and 250 A.

#### Partial discrimination

If the general rule presented above is not respected, discrimination is only partial. **Figure 19** indicates that between a 160 A circuit-breaker and a 250 A circuit-breaker fitted with a 250 A trip unit, discrimination is ensured up to a prospective short-circuit current of 4 800 A. This level is higher than that observed, under the same conditions, with standard Compact circuit-breakers.

#### Cascading with the Compact NS

Cascading, covered by standard NF C 15-100, enables the upstream circuit-breaker to help the

downstream device to break high short-circuit currents.

Note that this is detrimental to discrimination (except with the SELLIM system).

For the Compact NS, cascading in no way modifies the total and partial discrimination characteristics mentioned above.

A Compact NS circuit-breaker can however always assist a downstream circuit-breaker of a different type and with insufficient breaking capacity.

## 4.3 Combination with traditional protective devices

#### Standard circuit-breakers

In an existing installation, the highly limiting Compact NS circuit-breakers may be used for extensions or to replace existing circuit-breakers

without reducing the previous discrimination limit. On the contrary, if the new circuit-breaker is installed:

■ downstream, its current-limiting capacity can only improve the discrimination level, possibly to

the point of making discrimination total (see **fig. 20**),

■ upstream, the discrimination level is at least equal to the previous level and the high current-limiting capacity of the Compact NS can be used to reinforce cascading.

■ the energy that flows through the fuse during the break.

To ensure discrimination between an upstream circuit-breaker and a fuse, the circuit-breaker trip unit must not react to the sum of these two energies.

### Fuses

The  $I^2 t = f(I_p)$  curves (supplied by manufacturers) concern:

■ the energy required to blow the fuse (prearcing),

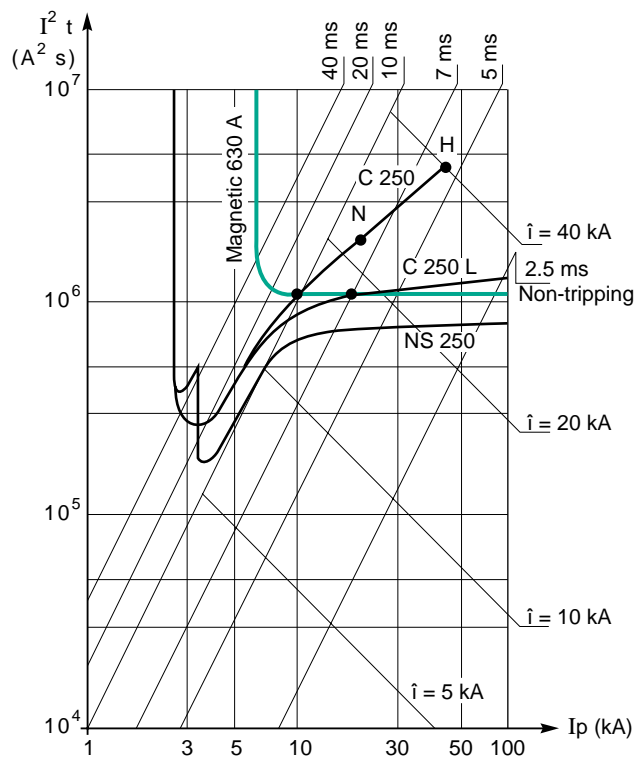

**Fig. 20:** replacement of a Compact C250 N, H or L by a Compact NS 250 provides improved discrimination. In this example, discrimination becomes total.

## 5 Conclusion

---

Using a few simple rules, highly limiting circuit-breakers that operate faster for higher prospective short-circuit currents can be implemented to provide total discrimination over several network levels. They may also implement time-discrimination techniques.

This is a major technical innovation that can be used to:

- considerably simplify discrimination studies,
- minimize electrodynamic forces, thermal stresses and voltage dips resulting from short-circuits.

This new discrimination technique, referred to as energy discrimination and based on total control over the energy let through by the circuit-breakers during breaking and on the sensitivity of the trip units to the same energy, is an important contribution to improving the availability of electrical power.

## 6 Appendix - indications concerning breaking with current limiting

**Figure 21** shows the currents and voltages for a half-period current-limiting phenomenon.

The short-circuit current ( $i_b$ ) obeys the following relationship:

$$U_r - U_a = r i + L \frac{di}{dt} \approx L \frac{di}{dt}$$

- at the beginning of the short-circuit,  $U_a$  is zero,  $i_b$  and  $i_p$  are equal and have identical slopes,

- when  $U_a$  is equal to the network voltage  $U_r$ ,  $i_b$  attains its maximum value ( $\hat{i}_b$ ) because its derivative is equal to zero,

- when  $U_a$  is greater than  $U_r$ ,  $i_b$  declines to zero at  $t_b$ .

The interrupted current wave is equivalent to a sinusoidal half wave with a period equal to twice the virtual breaking time ( $t_{vb}$ ).

With the above information, it is easy to determine the energy dissipated in the impedances of the concerned circuit.

Expressed in other terms, the formula for this energy, called the "breaking energy", is:

$$E_b = \int_0^{t_{vb}} i_b^2 dt$$

where  $i_b$  is a sinusoidal function:

$$E_b = \frac{1}{2} \hat{i}_b^2 t_{vb} \quad (1)$$

It is useful to express  $E_b$  as a function of  $I_p$  and the duration ( $t_{vb}$ ) of the break:

- $t_{vb} \geq 10$  ms

For such a duration, the fault current is low, the circuit-breaker contacts do not repel each other and there is therefore no arcing voltage:

$$i_b = i_p \text{ and } \hat{i}_b = \sqrt{2} I_p;$$

and formula 1 may be expressed as:

$$E_b = I_p^2 t \quad (2)$$

- $t_{vb} = 10$  ms

The circuit-breaker limits the fault current.

$i_b$  and  $i_p$  have the same initial slope, therefore:

$$\frac{di}{dt} = \omega I_p \sqrt{2} = \omega' \hat{i}_b$$

$$\text{where } \omega' = \frac{\pi}{t_{vb}}$$

$$t_{vb} \omega I_p \sqrt{2} = \pi \hat{i}_b$$

hence:

$$\hat{i}_b = t_{vb} 2 f I_p \sqrt{2}$$

or

$$t_{vb} = \frac{\hat{i}_b}{2 f I_p \sqrt{2}}$$

If we express equation (1) as:

$$\hat{i}_b^2 = \frac{2 E_b}{t_{vb}}$$

we obtain:

$$\frac{2 E_b}{t_{vb}} = (t_{vb} 2 f I_p \sqrt{2})^2$$

hence:

$$E_b = 4 f^2 I_p^2 t_{vb}^3 \quad (3)$$

Again on the basis of (1), but with  $\hat{i}_b$  in mind:

$$t_{vb} = \frac{2 E_b}{\hat{i}_b^2} = \frac{\hat{i}_b}{2 f I_p \sqrt{2}}$$

we obtain:

$$E_b = \frac{\hat{i}_b^3}{4 \sqrt{2} f I_p} \quad (4)$$

Formulas (3) and (4) can be used to plot the time and peak current curves.

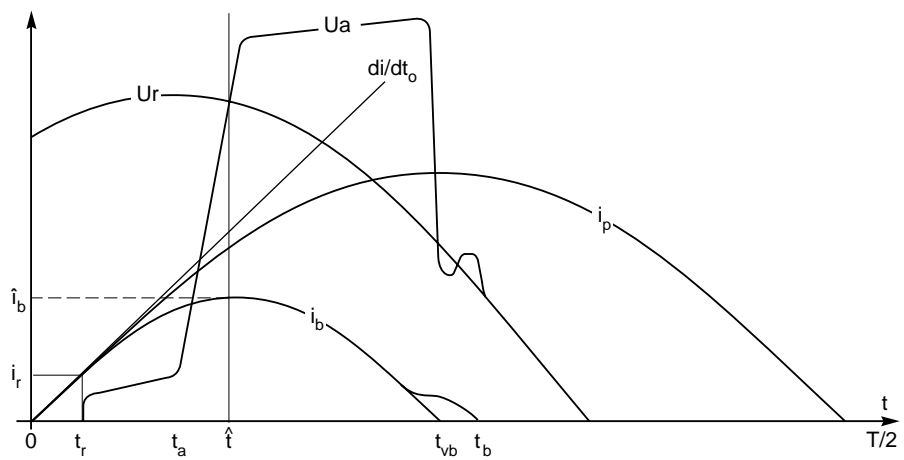

$U_a$ : arcing voltage  
 $U_r$ : network voltage  
 $i_p$ : prospective current  
 $i_b$ : break current (limited)  
 $\hat{i}_b$ : maximum break current  
 $i_r$ : contact repulsion current

$\hat{t}$ : time corresponding to  $\hat{i}_b$   
 $t_a$ : time at which the arc appears  
 $t_b$ : breaking time  
 $t_r$ : time at which contact repulsion occurs  
 $t_{vb}$ : virtual breaking time  
 $\omega$ : angular frequency of the interrupted wave

**Fig. 21:** breaking with current limitation.



